



SD Series Pizza Ovens Specifications

Model No. SD448, SD660, SD1048, SD1060

Phone: (631) 226-6688
FAX: (631) 226-6890



TOP
SD 448/1048

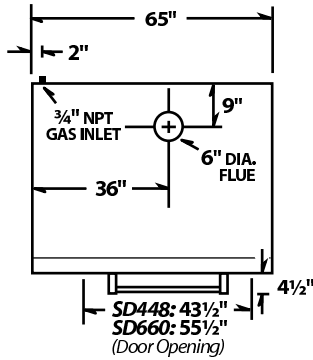

TOP
SD 660/1060

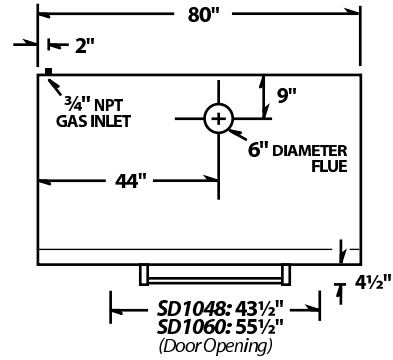

SIDE
SINGLE SD 448/660

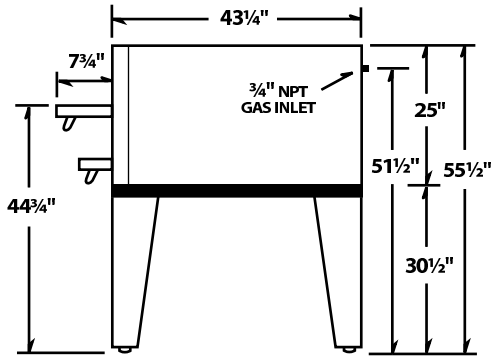

SIDE
SINGLE SD 1048/1060

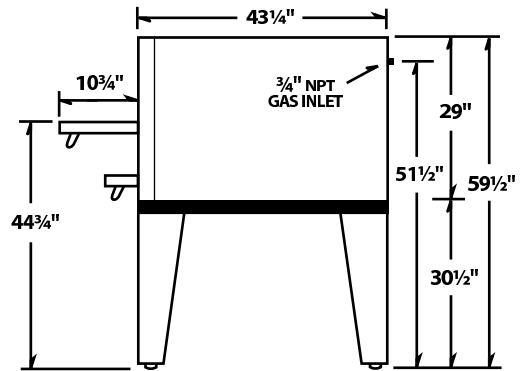

SIDE
STACKED SD 448/660

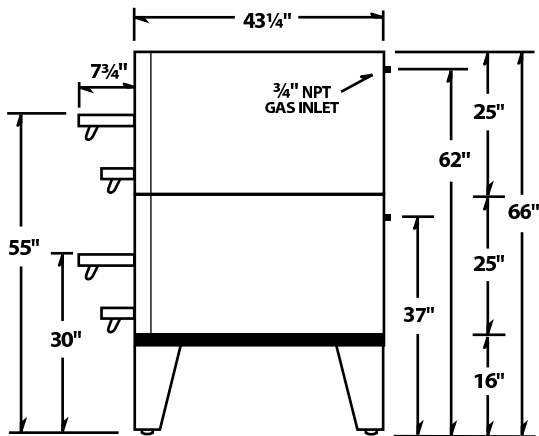

SIDE
STACKED SD 1048/1060

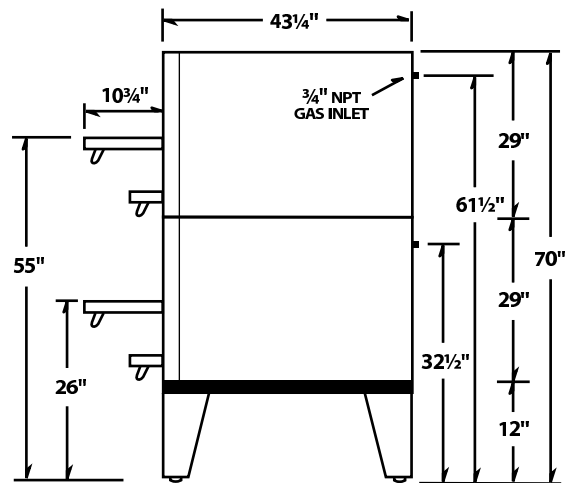

| | SD 448 Single | SD 448 Stacked | SD 660 Single | SD 660 Stacked | SD 1048 Single | SD 1048 Stacked | SD 1060 Single | SD 1060 Stacked | SD 1048 SD 448 | SD 1060 SD 660 |
|--------------------|---------------------------|-----------------------------------|-----------------------------|-------------------------------------|---------------------------|-----------------------------------|-----------------------------|------------------------------------|------------------------------------|-------------------------------------|
| Height | 55 1/2" | 66" | 55 1/2" | 66" | 59 1/2" | 70" | 59 1/2" | 70" | 68" | 68" |
| Depth x Length | 43 1/4" x 65" | 43 1/4" x 65" | 43 1/4" x 80" | 43 1/4" x 80" | 43 1/4" x 65" | 43 1/4" x 65" | 43 1/4" x 80" | 43 1/4" x 80" | 43 1/4" x 65" | 43 1/4" x 80" |
| Cooking Surface | 36" x 48" | 36" x 48" x 2 | 36" x 60" | 36" x 60" x 2 | 36" x 48" | 36" x 48" x 2 | 36" x 60" | 36" x 60" x 2 | 36" x 48" x 2 | 36" x 60" x 2 |
| BTUs | LP: 90,000 NAT: 95,000 | LP: 90,000 x 2 NAT: 95,000 x 2 | LP: 120,000 NAT: 130,000 | LP: 120,000 x 2 NAT: 130,000 x 2 | LP: 90,000 NAT: 95,000 | LP: 90,000 x 2 NAT: 95,000 x 2 | LP: 120,000 NAT: 130,000 | LP: 120,000 x 2 NAT: 95,000 x 2 | LP: 90,000 x 2 NAT: 130,000 x 2 | LP: 120,000 x 2 NAT: 130,000 x 2 |
| Shipping Weight | 1,075 lbs. | 2,100 lbs. | 1,400 lbs. | 2,750 lbs. | 1,150 lbs. | 2,250 lbs. | 1,475 lbs. | 2,900 lbs. | 2,175 lbs. | 2,825 lbs. |
| Pizza Pie Capacity | (4) 18" Pies | (8) 18" Pies | (6) 18" Pies | (12) 18" Pies | (4) 18" Pies | (8) 18" Pies | (6) 18" Pies | (12) 18" Pies | (8) 18" Pies | (12) 18" Pies |



8 Pie SD Series Pizza Ovens Specifications

Model No. SD866, SD1066

Phone: (631) 226-6688

FAX: (631) 226-6890



TOP
SD 866/1066

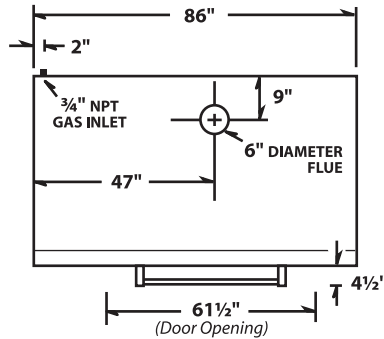

SIDE
SINGLE SD 866

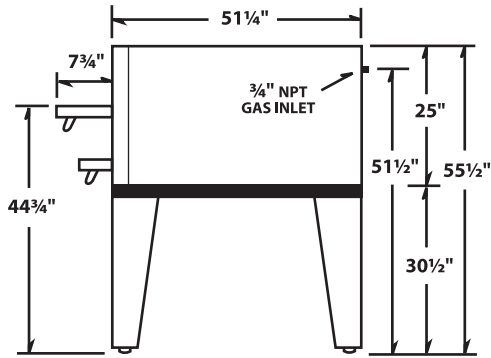

SIDE
SINGLE SD 10866

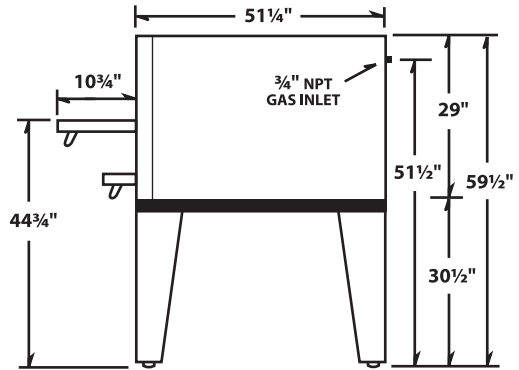

SIDE
STACKED SD 866

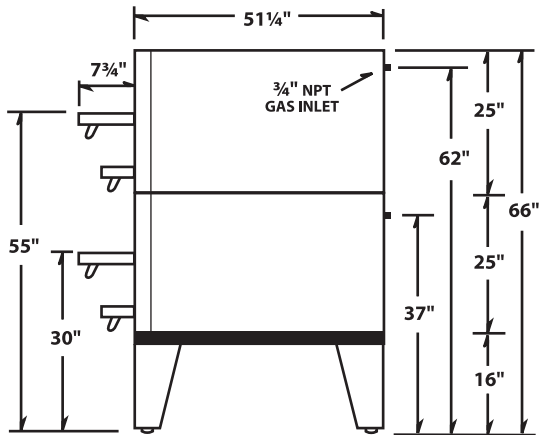

SIDE
STACKED SD 10866

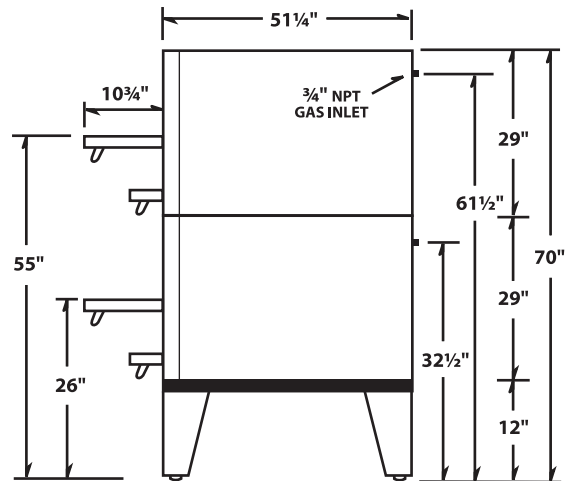

| | SD 866 Single | SD 866 Stacked | SD 10866 Single | SD 10866 Stacked |
|--------------------|-----------------------------|-------------------------------------|-----------------------------|-------------------------------------|
| Height | 55 1/2" | 66" | 59 1/2" | 70" |
| Depth x Length | 51 1/4" x 86" | 51 1/4" x 86" | 51 1/4" x 86" | 51 1/4" x 86" |
| Cooking Surface | 44" x 66" | 44" x 66" x 2 | 44" x 66" | 44" x 66" x 2 |
| BTUs | LP: 120,000 NAT: 130,000 | LP: 120,000 x 2 NAT: 130,000 x 2 | LP: 120,000 NAT: 130,000 | LP: 120,000 x 2 NAT: 130,000 x 2 |
| Shipping Weight | 1,625 lbs. | 3,200 lbs. | 1,900 lbs. | 3,350 lbs. |
| Pizza Pie Capacity | (8) 16" Pies | (16) 16" Pies | (8) 16" Pies | (16) 16" Pies |